

FAYMONVILLE

TRAILERS TO THE **MAX**

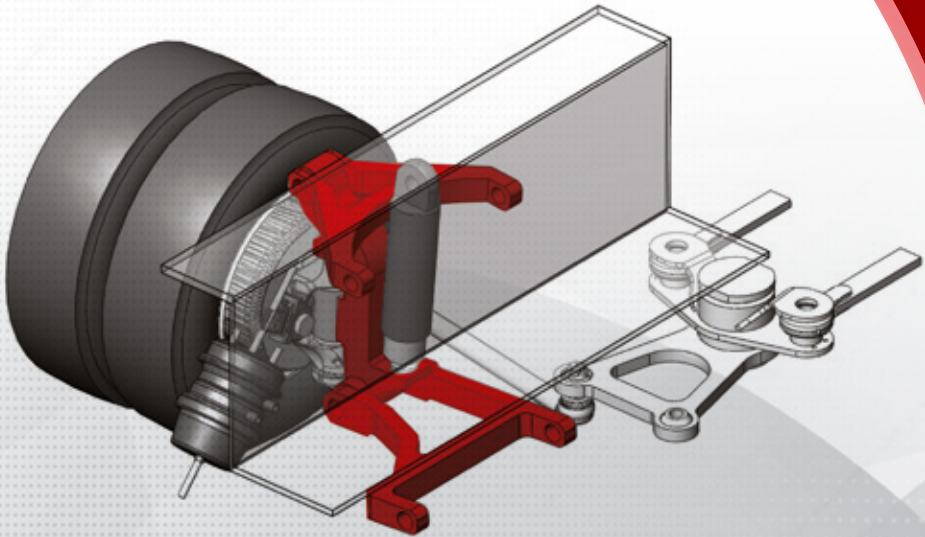

TWINAXLE II

SINGLE WHEEL SUSPENSION

- + Minimum loading height** (min. 780 mm)
- + Large axle stroke** (-70mm / + 245mm)
- + maximum steering angle** 57°



FAYMONVILLE DISTRIBUTION AG

Duarrefstrooss 8 | L-9990 WEISWAMPACH

T: +352 26 90 04 155 | F: +352 26 90 04 425 | sales@faymonville.com

- **Minimum loading height (min. 780 mm)**
also with double or triple-extendable semi-trailers
- **Large axle stroke (-70mm / + 245mm)**
and **maximum steering angle of 57°**
- **Increased payload**
- **Optimum driving stability**
- **Higher profitability and minimised maintenance costs**
- **Optimum km/cost ratio**
- **Wheel change is simple, since it is possible from the outside**
- **100% in-house production**
- **MAXProtect+ spray galvanising**
- **Aspöck Nordic plug connections and SAF components**



Last but not least, the 'Twin Axle II' enables higher axle loads, especially in Germany, where one can now **load two tonnes more per axle line**.

Lighter, more robust and more flexion-resistant central beams can be used thanks to the independent suspension and doing without a continuous axle body.

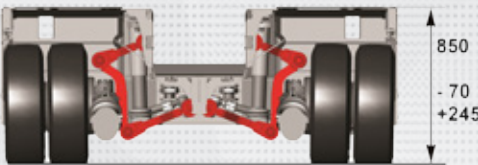

FAYMONVILLE is a full-range supplier – in every respect. And it is no different with the axle systems for the various types of semi-trailer. The 'Twin Axle II' system – i.e. the independent suspension – is a further part of the overall range.

From the rigid axle and the friction-steered axle to the hydraulic knuckle-steering axle and from the 'Twin Axle II' to the pendle axle, Faymonville's product range includes every axle system.

